

**THE FLORIDA STATE MUSEUM  
UNIVERSITY OF FLORIDA**



the florida  
state museum  
museum road  
university  
of florida  
gainesville  
32611  
904/392-1721

OFFICE OF THE DIRECTOR

March 23, 1981

MEMORANDUM

TO: Vice President Robert A. Bryan  
Dean Charles Sidman  
Dean John Woeste  
Dean F. A. Wood

FROM: F. Wayne King *FWK*

SUBJECT: Final Agreement on Transfer of the Herbarium to the Administrative Control of the Florida State Museum

Agreement has been reached on the final two points holding up the transfer of the Herbarium to the FSM -- i.e., the FSM will provide space for the Herbarium in any new museum building; and IFAS will continue to provide career service and other support to the herbarium -- so the transfer can finally take place.

The FSM commitment to providing space for the Herbarium, its staff, and other functions was explained in a 12 December 1980 draft memorandum from Wayne King to F. A. Wood and John Woeste, and is further elaborated in the attached Memorandum of Understanding.

The IFAS commitment to continue support to the Herbarium under the administration of the Museum was given in F. A. Wood's 16 March 1981 letter to W. King. It is further clarified by Vice President Robert Bryan's 16 March letter to Charles Woods. It is understood the three career service lines now provided to the Herbarium by IFAS -- Assistant in Botany (legislative position 91198), Secretary II (legislative position 92854), and Technician II (legislative position 92742) -- will remain within the IFAS budget function, but would be under the administrative supervision of the Museum. Similarly the Extension budget accounts that support the Herbarium, accounts 534911000 and 534911025 (LET), will be under the administrative control of the Museum. It is understood that the Museum will meet at least annually with IFAS to discuss the support needs of the Herbarium, just as it presently meets with the Office of Academic Affairs to discuss non-Herbarium needs.

When the Herbarium is transferred to the Museum, the subfaculty position of Assistant in Botany, legislative position 91198, will undergo a title change to Associate in Plant Identification. The new title is in keeping with other existing FSM subfaculty positions.

A Memorandum of Understanding on the transfer is attached for your review and signature. If everything is agreed now, the transfer could be accomplished by 1 April 1981.

FWK:ss

Attachment

MEMORANDUM OF UNDERSTANDING  
ON THE INTEGRATION OF THE HERBARIUM  
INTO THE FLORIDA STATE MUSEUM

- 1) The Herbarium is recognized as a unit of the Florida State Museum. The FSM Director will have ultimate administrative responsibility for the Herbarium, just as he has for other units within the Museum.
- 2) Within the Museum, the Herbarium will be a research and service subdivision of the Department of Natural Sciences, whose Chairman will integrate the herbarium and botanical interests into the overall operations of the Department. He also will coordinate with IFAS and the Department of Botany so as to assure the herbarium operations are fully supportive of and available to research and plant identification needs of those and other units of the University, State, and outlying research communities. The Chairman will also seek to assure that adequate support staff, equipment, and expenses are provided to the Herbarium. To that end he will make budget and staff requirements known to the FSM Director and to the IFAS Deans for Research and Extension Service.
- 3) A new position, Associate Curator of Botany and Keeper of the Herbarium, will be created within the FSM Department of Natural Sciences. The individual occupying this position will have primary responsibility for overall curation and operation of the Herbarium, including coordination with the Joint Curators of the various plant collections. The Curator/Keeper will conduct research in systematic botany, and will work with the FSM Natural Sciences Chairman, the Botany Department Chairman, and the Joint Curators to further develop an active program in systematic botany in the FSM and the University. Depending on the limitations set by curatorial duties, research responsibilities, and the interests of the other departments, the Curator/Keeper will be expected to participate in the teaching function of the Botany Department or IFAS.
- 4) Botany staff who oversee the curation of particular plant collections will have adjunct appointments in the FSM and will carry the joint curatorial title. These individuals will be invited to attend FSM Natural Sciences faculty meetings and to participate in faculty affairs within the Department (including voting on all matters except tenure and promotion) just as is currently the case with Dana Griffin. These courtesy appointments will be reviewed each year by the Department of Natural Sciences.
- 5) IFAS career service staff responsible for plant identification, herbarium secretarial and technician services will be under the administrative supervision of the Museum. The FSM will maintain the present level of plant identification service or greater.
- 6) The physical transfer of the Herbarium from Rolfs Hall to J. C. Dickinson, Jr., Hall (the Museum building) must await construction of additional space within the FSM. Any such move must involve not only the plant collections and herbarium equipment, but also office and laboratory space for the Herbarium curators and Plant Identification staff.

Physical separation from the Herbarium will severely hamper the staff in carrying out its research and plant identification duties. Therefore, the Florida State Museum guarantees to provide, in any new building, space for both the plant collections and associated equipment and library, and for offices and laboratory space for the curators and plant identification and career service staff. In keeping with existing practice, the FSM also will provide office and laboratory space in or near the Herbarium for some graduate students in systematic botany. Finally, the FSM will endeavor to provide additional office and laboratory space for visiting scientists using the Herbarium. The FSM is not able to guarantee space for the visiting scientists or for an exact number of graduate students, since the size of any future expansion of museum facilities depends on the success of our fund-raising efforts. However, as a demonstration of the FSM's commitment to providing as much space as possible, it should be noted that up until this year, offices for visiting scientists have been provided in both the Department of Natural Sciences and the Department of Social Sciences. Expansion of the Museum program during 1980 necessitated the placement of a staff member in one visiting scientist office. In addition, office space is provided for from one to four graduate students in each of the existing research collection areas, and laboratory space and equipment is provided on an "as-needed" basis for any student who uses the collections but has an office in another unit of the University. The herbarium and plant identification staff will be involved actively in planning future space.

The target date for ground-breaking for the expanded FSM building is 1986.

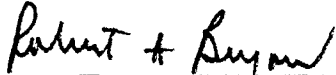
  
\_\_\_\_\_  
Dr. Robert A. Bryant  
Vice President of Academic Affairs

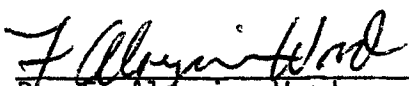
 3-23-81  
\_\_\_\_\_  
Dr. F. Algysius Wood  
Dean for Research, IFAS

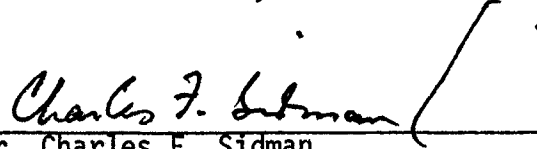
  
\_\_\_\_\_  
Dr. Charles F. Sidman  
Dean, Liberal Arts and Sciences

 3-23-81  
\_\_\_\_\_  
Dr. John T. Woeste  
Dean for Extension, IFAS

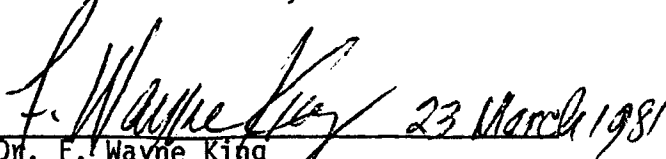
 23 March 1981  
\_\_\_\_\_  
Dr. F. Wayne King  
Director, Florida State Museum

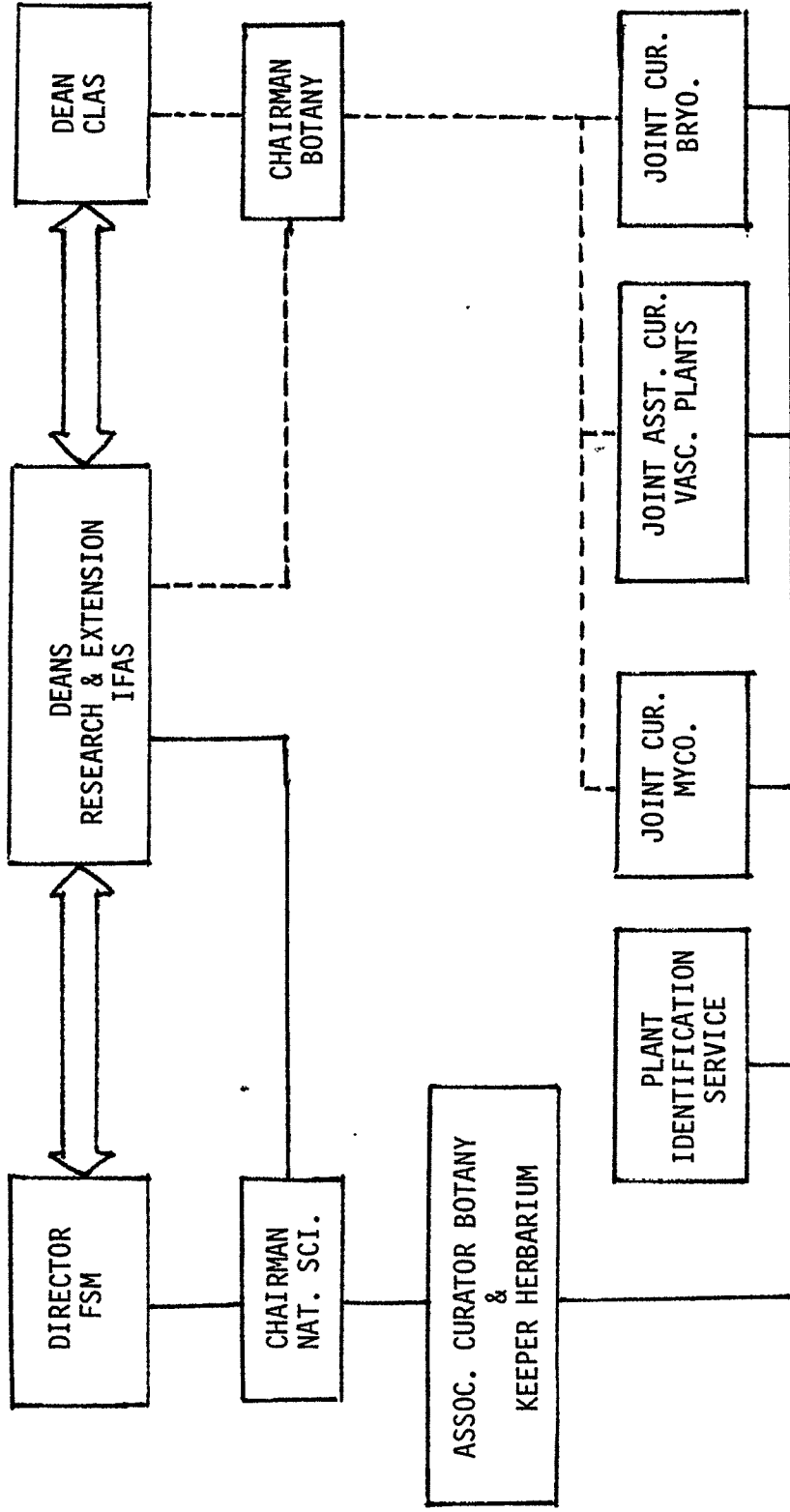

Solid lines indicate reporting responsibilities for herbarium curatorial functions, plant identification, and for research within the FSM program. Dashed lines indicate reporting responsibilities for teaching, research, or related functions outside the FSM program. The large arrows simply indicate channels of communication that are always available to address special concerns.

THE FLORIDA STATE MUSEUM  
UNIVERSITY OF FLORIDA

OFFICE OF THE DIRECTOR



the florida  
state museum  
museum road  
university  
of florida  
gainesville  
32611  
904/392-1721

April 16, 1981

MEMORANDUM

TO: Vice President Robert A. Bryan  
Dean Charles Sidman  
Dean John Woeste  
Dean F. W. Wood

FROM: F. Wayne King *W.K.*

SUBJECT: Correction of a typographical error in the Final Agreement  
on the Transfer of the Herbarium

The Final Agreement on the Transfer of the Herbarium to the Administrative Control of the FSM dated 23 March 1981 contains a typographical error relative to the Assistant in Botany position (legislative position 91198). This is a subfaculty position as correctly stated in the last paragraph of page one of the memorandum. In line four of the third paragraph of that memorandum and in paragraph 5 of the Memorandum of Understanding this position is incorrectly identified as a career service line. This is an unfortunate error that in no way denigrates the position or implies that it is being downgraded. The legislative position 91198 will carry a new title in the FSM, that of Associate in Plant Identification. This will remain a subfaculty position.

FWK:ss

cc: Dr. William Stern  
Dr. Charles Woods  
bcc: Dr. Gene Hemp